

Client: Automotive Parts

Location: USA

Date: 28-Oct-14

Contact: Value Stream Manager





Phone: (555) 555-5555

Report #: CI-213

Problem:

After implementing KPI monitoring on three Supply systems to the plant, the inability to maintain control of the supply concentration was identified as a root cause to significant concentration variability in the machining process, leading to excessive coolant usage and poor concentration compliance.

Objectives:



-  Reduce variability in concentration of the supply systems
-  Improve operational compliance at machining centres
-  Improve process capability and then tighten control limits to reduce waste
-  Monitor reduction in coolant usage

Current State:



Performance Results	August - September
Make-up Concentration Delta :	18.3%
Make-up Concentration Average:	5.65%
Make-up Control Plan Compliance to :	9%
Overall Plant Wide Control Plan Compliance :	21.5%
Average Daily Coolant Consumption :	146 G/Day
Average Monthly Coolant Consumption :	4,187 G/Month
Average Monthly Coolant Spend :	\$53,390 / Month

*All data from Zimmark's fluidperformancemanagement.com

Investigation Observations:

-  Current Make-up tank infrastructure has a 3000 gallon RAW coolant bulk tank gravity feeding three proportioning pumps to three blend tanks.
-  The RAW coolant is gravity fed to all three pumps, when coolant deliveries are made to the 3000 gallon tank, the fluid pressure exceeds the proportioning pump's check valve allowing excess coolant to pass through the pump. As a result, the Make-up tanks run at higher concentrations and consume more coolant than required.

Infra Structure changes made:

-  Install a small 55 gallon coolant reservoir tank after the 3000 gallon tank with a float valve to allow coolant to accumulate
-  Draw coolant with the three proportioning pumps from the 55 gallon tank so that the fluid going to the pumps is not under high pressure allowing the pump check valve to operate correctly
-  Replace existing old and damaged pumps, with new lower cost (~\$400 savings/pump) proportioning pumps



Implemented changes:

Identified Engineering Design changes shown in Blue

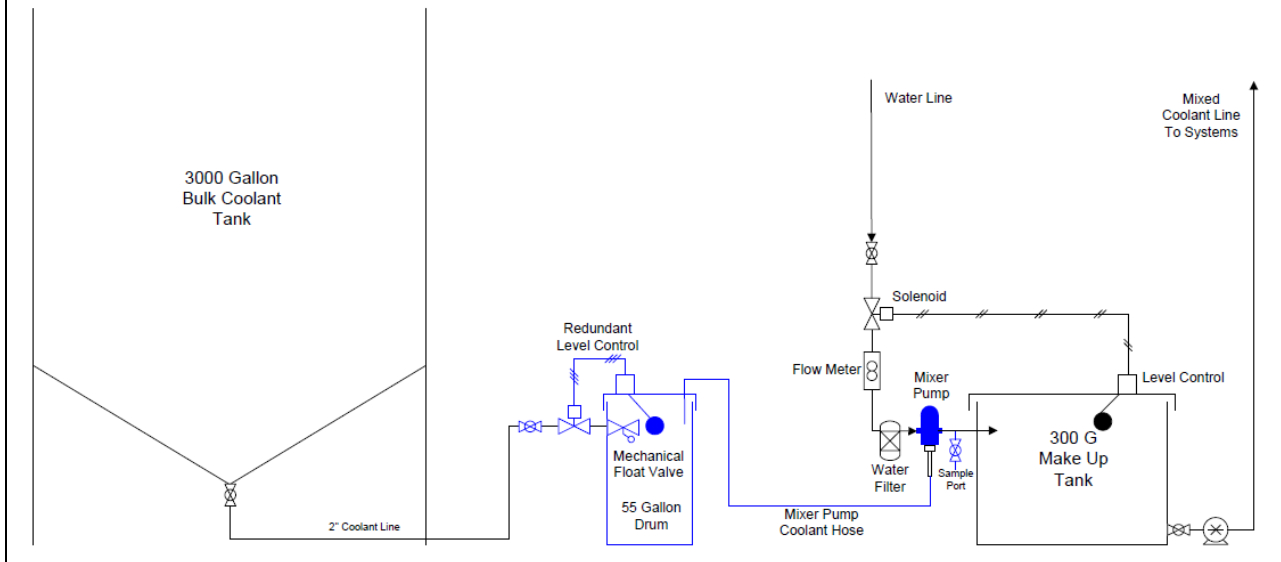

Results:

Performance Results	Aug - Sept	Oct - Nov	Improvement
Make-up Concentration Delta :	18.3%	1.6%	17.1%
Make-up Concentration Average:	5.65%	1.15%	4.5%
Make-up Control Plan Compliance:	9%	73%	64%
Overall Plant Wide Control Plan Compliance :	21.5%	54.2%	32.7%
Average Daily Coolant Consumption :	146 G/Day	104 G/Day	42 G/Day
Average Monthly Coolant Consumption :	4,187 G/Month	3172 G/Month	1,015 G/Month
Average Monthly Coolant Spend :	\$53,390 / Month	\$40,443 / Month	\$12,941 / Month

*All data from Zimmark's *fluidperformancemanagement.com*

Location ID : 180
Unit Name : Makeup B

Brass Tag : B
Concentration
Location ID : 160
Unit Name : Makeup C

Brass Tag : C
Concentration

Location ID : 170
Unit Name : Makeup A
Brass Tag : A
Concentration

